



### CAPACITOR-BASED DC-UPSs

- Built-in Capacitors as Energy Source (EDLC Electrochemical Double Layer Capacitors)
- Wide Temperature Range from -40°C to +60°C
- Typically >10 Years Operational Lifetime Expectancy
- Regulated Output Voltage in Buffer Mode
- No Ventilated Cabinets Required (No Generation of Hydrogen as VRLA batteries do)
- Active Balancing for Longest Life and Buffer Times
- Short Charging Time, Unit is Rapidly Back in Ready Mode
- Output is Decoupled from the Input to Separate Load Circuits into Buffered and Non-buffered Sections
- Supports PC-Mode Function
- 3 Year Warranty

### GENERAL DESCRIPTION

The DIMENSION UC-Series are DC-UPSs utilizing Electrochemical Double Layer Capacitors (EDLC), commonly known as Ultracapacitors or Supercapacitors, which are installed inside the DC-UPS. They can bridge power failures or voltage fluctuations and supply voltage to the DC 24V bus for a certain period, which allows for a safe shut-down of the system. Expensive downtimes, long restart cycles and loss of data can be avoided.

In times when the power supply provides sufficient voltages, the DC-UPS stores energy in the capacitors. In case of a mains voltage fault, this energy is released to the DC bus in a regulated process.

The DC-UPSs are maintenance-free and have a similar lifetime expectancy as power supplies. No regular replacement of the capacitors is necessary as is required for battery based DC-UPS systems. The wide temperature range from -40°C to +60°C makes the unit suitable for many applications.

The DC-UPSs come in two versions which differ in the size of the installed capacitors.

### ORDER NUMBERS

DC-UPS	<b>UC10.241</b>	6kWs energy storage
	<b>UC10.242</b>	12kWs energy storage
Accessory	ZM2.WALL	Panel/ wall-mount bracket

### SHORT-FORM DATA

Nominal voltage	DC 24V	
Output current	15A	continuous
Buffer voltage	22.0 - 22.65V	fixed, 15A – 0A
Input current	typ. 1.1A	during charging, output current not included
Capacitor size	6kWs	UC10.241
	12kWs	UC10.242
Charging time	16 minutes	UC10.241
	32 minutes	UC10.242
Buffer time	16.5s at 10A	UC10.241
	33s at 10A	UC10.242
Power losses	4.6W	in normal mode at 10A output current
Temperature range	-40°C to +60°C	operational
Dimensions	126x124x117mm	UC10.241
W x H x D	198x124x117mm	UC10.242
Weight	1150g / 2.54lb	UC10.241
	1720g / 3.79lb	UC10.242

### MARKINGS



### INDEX

	Page		Page
1. Intended Use .....	3	19. Approvals .....	19
2. Installation Notes .....	3	20. RoHS, REACH and Other Fulfilled Standards ..	19
3. Input .....	4	21. Physical Dimensions and Weight .....	20
4. Output .....	5	22. Accessories .....	21
5. Charging .....	7	22.1. ZM2.WALL – Wall-Mounting Bracket .....	21
6. Buffer Time .....	8	23. Application Notes .....	22
7. Ready and Buffering Relay Contact .....	9	23.1. External Input Protection .....	22
8. Inhibit Input .....	9	23.2. Output Circuit Breakers .....	22
9. PC-Mode .....	10	23.3. Parallel Use to Increase Output Current ..	22
10. Efficiency and Power Losses .....	11	23.4. Parallel Use for Redundancy .....	23
11. Lifetime Expectancy and MTBF .....	12	23.5. Parallel Use for Longer Buffer Times .....	23
12. Functional Diagram .....	13	23.6. Series Use for 48V Applications .....	24
13. Terminals and Wiring .....	14	23.7. Using the Inhibit-Input .....	24
14. Front Side and User Elements .....	15	23.8. External Controlled Delayed Shut-down ..	25
15. EMC .....	16	23.9. What do KJ and KWS mean? .....	26
16. Environment .....	17	23.10. Troubleshooting .....	27
17. Protection Features .....	18		
18. Safety Features .....	18		

The information presented in this document is believed to be accurate and reliable and may change without notice. No part of this document may be reproduced or utilized in any form without permission in writing from the publisher.

### TERMINOLOGY AND ABBREVIATIONS

<b>Normal mode</b>	Describes a condition where the capacitor is charged, the input voltage is in range and the output is loaded within the allowed limits.
<b>Buffer mode</b>	Describes a condition where the input voltage is below the transfer threshold level, the unit is running on capacitor (buffering) and the output is loaded within the allowed limits.
<b>Charging mode</b>	Describes a condition where the capacitor is being charged, the input voltage is in range and the output is loaded within the allowed limits.
<b>Inhibit mode</b>	Describes a condition where buffering is disabled on purpose (e.g. for service actions)
<b>T.b.d.</b>	To be defined, value or description will follow later.
<b>AC 24V</b>	A figure displayed with the AC or DC before the value represents a nominal voltage with standard tolerances included. E.g.: DC 12V describes a 12V battery disregarding whether it is full (13.7V) or flat (10V)
<b>24Vac</b>	A figure with the unit (Vac) at the end is a momentary figure without any additional tolerances included.
<b>may</b>	A key word indicating flexibility of choice with no implied preference.
<b>shall</b>	A key word indicating a mandatory requirement.
<b>should</b>	A key word indicating flexibility of choice with a strongly preferred implementation.

### 1. INTENDED USE

This device is designed for installation in an enclosure. Use an appropriate enclosure which protects against mechanical, electrical and fire hazards.

This device is intended for professional use in areas such as in industrial control, office, communication, and instrumentation equipment.

Do not use this device in equipment or systems where malfunction may cause severe personal injury or threaten human life.

### 2. INSTALLATION NOTES

This device may only be installed and put into operation by qualified personnel.

The input must be powered from a SELV or PELV power source.

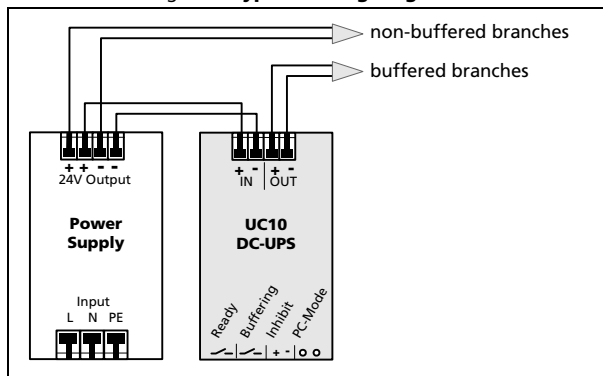
This device does not contain serviceable parts. The tripping of an internal fuse is caused by an internal defect. If damage or malfunction should occur during installation or operation, immediately turn power off and send unit to the factory for inspection.

Mount the unit on a DIN-rail so that the power terminals are located on the top of the unit.

This device is designed for convection cooling and does not require an external fan. Do not obstruct airflow and do not cover ventilation grid (e.g. cable conduits) by more than 15%!

Keep the following installation clearances: 40mm on top, 20mm on the bottom, 5mm on the left and right sides are recommended when the device is loaded permanently with more than 50% of the rated power. Increase this clearance to 15mm in case the adjacent device is a heat source (e.g. a power supply).

Fig. 2-1 Typical wiring diagram



The EDLC (storage capacitors) contain Acetonitrile and Tetraethylammonium-tetrafluoroborate. These components are declared as non-dangerous goods in regards to shipment. A safety datasheet can be provided when required.

**⚠ WARNING** Risk of electrical shock, fire, personal injury or death.

- Turn power off before working on the device. Protect against inadvertent re-powering.
- Make sure that the wiring is correct by following all local and national codes.
- Do not modify or repair the unit.
- Do not open the unit as hazardous energy may be present inside.  
Info for service personnel: Before opening the unit, wait at least 45 minutes after disconnecting the unit from input power so that the remaining capacitor charge has completely been discharged.
- Use caution to prevent any foreign objects from entering the housing.
- Do not use in wet locations or in areas where moisture or condensation can be expected.
- Do not touch during power-on, and immediately after power-off. Hot surfaces may cause burns.

**Notes for use in hazardous location areas:**

The DC-UPS is suitable for use in Class I Division 2 Groups A, B, C, D locations and for use in Group II Category 3 (Zone 2) environments and are evaluated according to EN 60079-0 and EN 60079-15.

**WARNING EXPLOSION HAZARDS!**

Substitution of components may impair suitability for this environment. Do not disconnect the unit or change unit settings unless power has been switched off or the area is known to be non-hazardous.

A suitable enclosure must be provided for the end product which has a minimum protection of IP54 and fulfils the requirements of the EN 60079-15.

### 3. INPUT

Input voltage	nom.	DC 24V $-20\%/+25\%$	
Input voltage ranges	typ.	22.5 to 30Vdc	continuous operation temporarily allowed, no damage to the unit Between 30 and 35Vdc buffering is not possible, the unit indicates "Check Input Voltage" with the red LED on the front
	max.	30 to 35Vdc	
Transfer threshold voltage		22.45V $\pm 1\%$	at no load
	typ.	22.55V	at 10A buffer current
	typ.	22.60V	at 15A buffer current
	max.	22.88V	at 15A buffer current
The transfer threshold voltage describes the input voltage, where the unit switches into buffer mode and delivers output voltage from the capacitors if the input was above the turn-on level before and all other buffer conditions are fulfilled.			
Turn-on voltage	typ.	22.8Vdc	The output does not switch on if the input voltage is below this level.
	max.	23.0V	
Allowed voltage between input and earth (chassis)	max.	60Vdc or 42.4Vac	continuous, IEC 62103
Current consumption	typ.	0.09A	capacitors charged, output current not included
	typ.	1.1A	during charging, output current not included
	max.	1.3A	
Input current	max.	17A	during charging an full output current
Return current	typ.	-9mA	Leakage current to input in buffer mode
	max.	-11mA	
Suitable power sources on input	no limitation in the maximum power supply current		

Fig. 3-1 Input voltage range

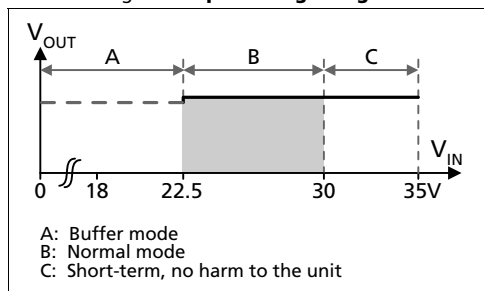
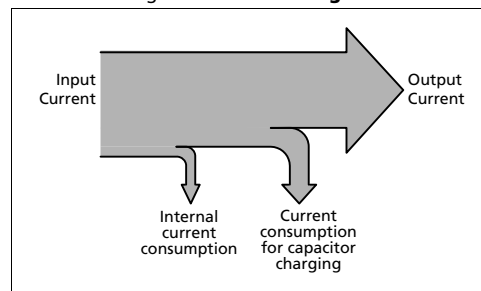


Fig. 3-2 Current budget



### 4. OUTPUT

The output section of the DC-UPS is fully controlled and is equipped with an electronic current limitation. A current overloading of the DC-UPS cannot happen, independent of which sizes of power supplies are used on the input of the DC-UPS.

The current limitation works in a switching mode which reduces the power losses and heat generation to a minimum.

#### Output in normal mode:

In normal mode (and also in charging mode), the output voltage is slightly lower as the input voltage. The output voltage follows the input voltage reduced by the input to output voltage drop.

Input to output voltage drop	max.	0.3V 0.45V	at 10A output current at 15A output current, see Fig. 4-1
Ripple & noise voltage	max.	30mVpp	at 20Hz to 20MHz, 50Ohm measurement. This figure indicates the ripple & noise voltage which is produced by the DC-UPS. It can be higher if the supplying source has a higher ripple and noise voltage.
Output current	nom.	15A	continuously allowed for the entire voltage range
Output power	nom.	360W	at 24V
Overload behavior		continuous current	see Fig. 4-2
Current limitation	typ. min.	16A 15A	see Fig. 4-2
Short-circuit current	min. max.	17.9A 21.0A	load impedance 100mOhm, see Fig. 4-2 load impedance 100mOhm, see Fig. 4-2
Output capacitance	typ.	1 500µF	included inside the DC-UPS
Capacitive and inductive loads		No limitation	

#### Output in buffer mode:

The output voltage is fully regulated in buffer mode.

The unit switches into buffer mode, when the input voltage falls below the transfer threshold input voltage level, The buffer voltage is slightly lower than this threshold input voltage. The unit switches back to normal mode, as soon as the input voltage exceeds the transfer threshold voltage, which is specified in the input section.

Output voltage	typ.	22.45V ±1% 22.25V ±1% 22.12V ±1%	at no load at 10A buffer current at 15A buffer current
Ripple & noise voltage	max.	30mVpp	at 20Hz to 20MHz, 50Ohm measurement
Output current	nom.	15A	continuously allowed
Output power	nom.	360W	at 24V
Overload behavior		continuous current	see Fig. 4-2
Current limitation	typ. min.	16A 15A	see Fig. 4-2
Short-circuit current	min. max.	17.9A 21.0A	load impedance 70mOhm, see Fig. 4-2 load impedance 50mOhm, see Fig. 4-2
Capacitive and inductive loads		No limitation	

Fig. 4-1 Input to output voltage drop in normal mode, typ.

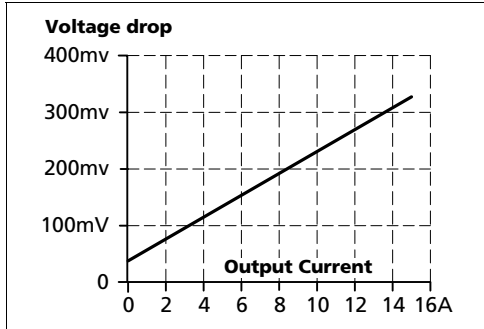


Fig. 4-2 Output characteristic and overload behavior in normal and buffer mode, typ.

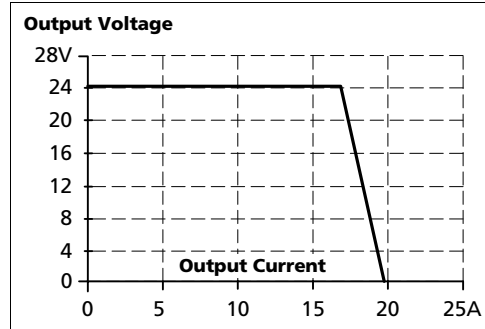


Fig. 4-3 Transition from buffer mode to normal mode and vice versa, definitions

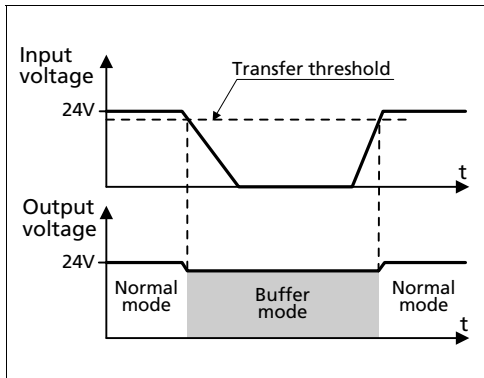
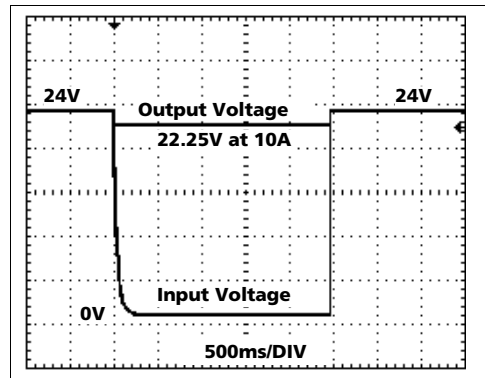


Fig. 4-4 Transfer behavior, typ.



### 5. CHARGING

During charging, the DC-UPS consumes additional current from the input. See chapter "Input".

When charging is completed, the "Ready LED" stops flashing and is on solid and the "Ready relay contact" closes.

		<b>UC10.241</b>	<b>UC10.242</b>	
Charging time initial charging <sup>*)</sup>	typ.	16 minutes	32 minutes	when capacitor is completely discharged
Charging time recharging <sup>**)</sup>	typ.	1 minute 50s	1 minute 50s	after discharging with 10A for 10s
	typ.	3 minutes 50s	7 minutes 40s	after discharging with 10A until buffering stops
	typ.	4 minutes 40s	9 minutes 40s	after discharging with 5A until buffering stops
	typ.	5 minutes 40s	11 minutes 15s	after discharging with 1A until buffering stops
Allowed number of charging/ discharging cycles		no limitation	no limitation	

\*) Initial charging means that no input voltage was applied for several hours or longer and the capacitor is completely discharged by the internal electronics.

\*\*\*) Recharging means that the electronics inside the DC-UPS has not completely discharged the capacitor. The values in the table apply when the input voltage is applied immediately after buffering has stopped.

**Note:**

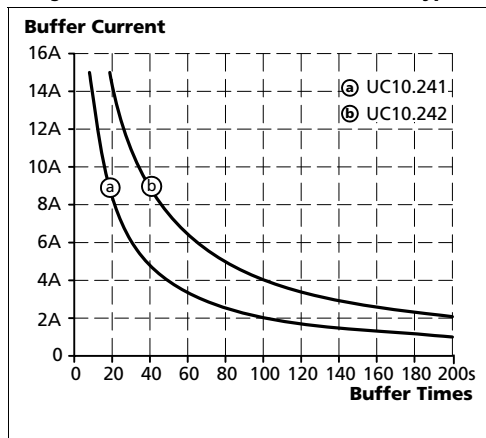
At the end of the charging process the active balancing circuit reduces the charging current periodically, which can be seen as current oscillations on the input current.

### 6. BUFFER TIME

The following times are typical values for a new product and the aging effect during operation is not included. More information about the reduction of the buffer time over the life of the product can be found in the chapter 11 "Lifetime Expectancy and MTBF".

		<b>UC10.241</b>	<b>UC10.242</b>	
Buffer Time	typ.	1650s	3300s	at 0A buffer current
	typ.	340s	680s	at 0.5A buffer current
	typ.	200s	400s	at 1A buffer current
	typ.	68s	136s	at 3A buffer current
	typ.	39s	78s	at 5A buffer current
	typ.	26s	53s	at 7A buffer current
	typ.	16.5s	33s	at 10A buffer current
	typ.	9s	18s	at 15A buffer current

Fig. 6-1 **Buffer time vs. buffer current, typ.**



### 7. READY AND BUFFERING RELAY CONTACT

The DC-UPSs are equipped with two independent relay contacts for remote monitoring and controlling of the unit.

#### Ready contact

Contact is closed when capacitor is completely charged, input voltage is sufficient and inhibit signal is not active.

Contact ratings	max.	60Vdc 0.3A, 30Vdc 1A, 30Vac 0.5A	resistive load
	min.	1mA at 5Vdc	min. permissible load
Isolation voltage	500Vac, signal port to power port		

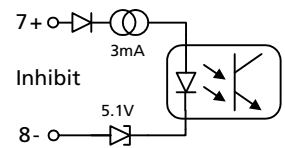
#### Buffering contact

Contact is closed when unit is buffering.

Contact ratings	max.	60Vdc 0.3A, 30Vdc 1A, 30Vac 0.5A	resistive load
	min.	1mA at 5Vdc	min. permissible load
Isolation voltage	500Vac, signal port to power port		

### 8. INHIBIT INPUT

The inhibit input disables buffering. In normal mode, a static signal is required. In buffer mode, a pulse with a minimum length of 250ms is required to stop buffering. The inhibit is stored and can be reset by cycling the input voltage. See also section 23.7 for application notes.

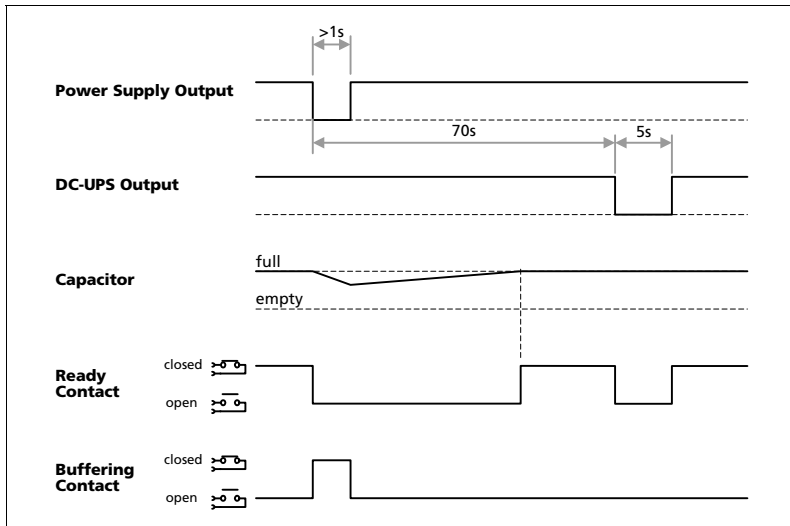


Signal voltage	max.	35Vdc
Signal current	max.	6mA, current limited
Inhibit threshold	min.	6Vdc, buffering is disabled above this threshold level
	max.	10Vdc
Isolation voltage	500Vac, signal port to power port	

### 9. PC-MODE

The PC-mode always turns the output off for at least 5s after a buffer event lasting longer than 1s, independent of whether the 24V may have recovered during this time. This function ensures that the PC gets a restart signal. To enable a safe shut-down of the system, the forced turn off of the output is delayed with a constant time of 70s. To activate the PC-mode, connect the two pins marked with "PC-mode" together on the signal connector together. If the reset is to be controlled by the PC and not the DC-UPS, a wiring option called "external controlled delayed shut-down" is available. See section 23.8 for details.

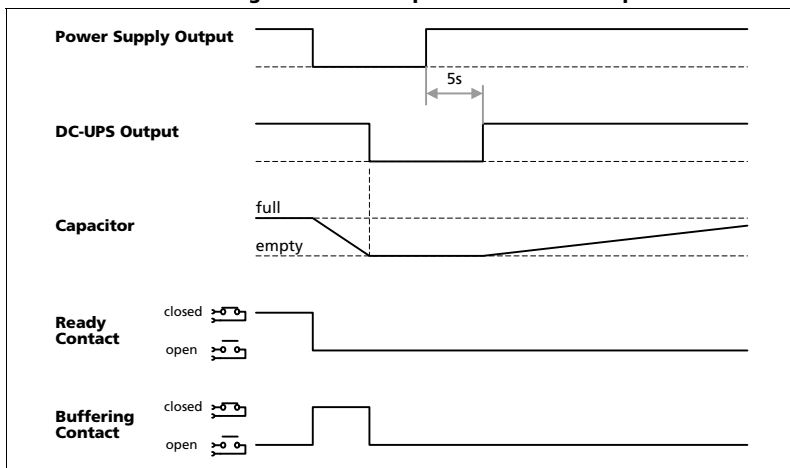
Fig. 9-1 **PC-Mode - Buffer event ends before buffer capacitors are discharged and buffer event is shorter than 70s**



**Example A:**

The buffer event is longer than 1s and ends before the buffer capacitors are fully discharged. After 70s of the beginning of the buffer event, the output of the DC-UPS will be switched off for 5s.

Fig. 9-2 **PC-Mode - Buffer event discharges the buffer capacitors before the input recovers**



**Example B:**

The buffer event lasts longer than the buffer capacitors can supply the output. The buffer capacitors are fully discharged before the input voltage recovers. The DC-UPS output will turn-on earliest 5s after the power supply output voltage has recovered.

### 10. EFFICIENCY AND POWER LOSSES

Efficiency	typ.	97.8%	Normal mode, 10A output current, capacitor fully charged
	typ.	97.8%	Normal mode, 15A output current, capacitor fully charged
Power losses	typ.	2.9W	Normal mode, 0A output current, capacitor fully charged
	typ.	4.6W	Normal mode, 10A output current, capacitor fully charged
	typ.	7.7W	Normal mode, 15A output current, capacitor fully charged
	typ.	5.0W	During charging, 0A output current

Fig. 10-1 Efficiency vs. output current in normal mode, typ.

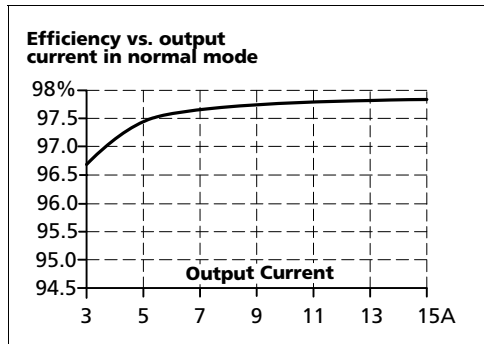
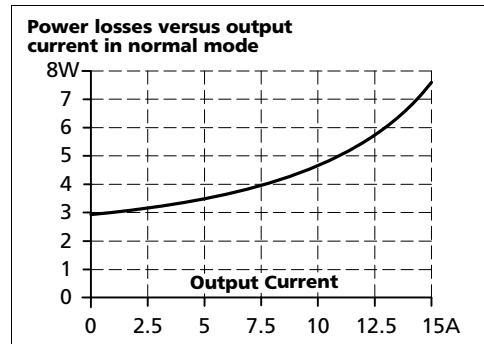


Fig. 10-2 Power losses vs. output current in normal mode, typ.



### 11. LIFETIME EXPECTANCY AND MTBF

The lifetime expectancy of the DC-UPS is predominantly affected by the storage capacitors. The biggest influence in lifetime is a combination of operating voltage and operating temperature of these capacitors. To gain longest lifetimes, PULS does not utilize the full allowed working voltage for these capacitors and therefore accepts a slightly shorter buffer time.

The EDLC's do not experience a true end-of-life, rather the capacitance continually degrades over the life of the DC-UPS. The typical degradation behavior resembles that of an exponential decay in the first couple of 1000 hours followed by a linear degradation. The majority of the capacitance reduction occurs during the initial use of the DC-UPS and this change in performance then levels off over time. When working with the specified lifetime numbers, the remaining capacity must always be taken into account. The buffer time correlates linearly to the capacity.

The ultracapacitors have an almost unlimited shelf life (unlike batteries) when stored uncharged at 25°C.

The number of charge/ discharge cycles does not have an impact on the lifetime as long as the number of cycles does not exceed 100 000. This should not be the case for a typical backup operation.

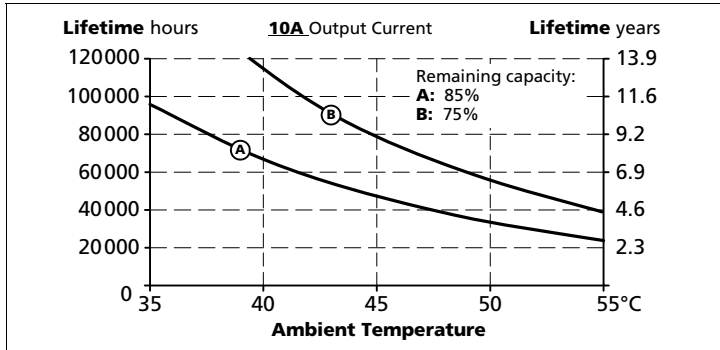
Lifetime	UC10.241		UC10.242		
	85%	75%	85%	75%	
Remaining capacity					
Lifetime expectancy *)	186 000h	324 000h	186 000h	324 000h	at 24V, 10A, 25°C
	155 000h	270 000h	155 000h	270 000h	at 24V, 15A, 25°C
	66 000h	115 000h	66 000h	115 000h	at 24V, 10A, 40°C
	55 000h	96 000h	55 000h	96 000h	at 24V, 15A, 40°C
	23 000h	40 000h	23 000h	40 000h	at 24V, 10A, 55°C
	19 000h	34 000h	19 000h	34 000h	at 24V, 15A, 55°C

MTBF	UC10.241		UC10.242		
MTBF **) SN 29500, IEC 61709	1 519 000h	1 515 000h	at 24V, 10A, 25°C		
	1 443 000h	1 439 000h	at 24V, 15A, 25°C		
	899 000h	895 000h	at 24V, 10A, 40°C		
	854 000h	850 000h	at 24V, 15A, 40°C		
MTBF **) MIL HDBK 217F	525 000h	524 000h	at 24V, 10A, 25°C; Ground Benign GB25		
	498 000h	497 000h	at 24V, 15A, 25°C; Ground Benign GB25		
	385 000h	384 000h	at 24V, 10A, 40°C; Ground Benign GB40		
	365 000h	364 000h	at 24V, 15A, 40°C; Ground Benign GB40		
	125 000h	125 000h	at 24V, 10A, 25°C; Ground Fixed GF25		
	118 000h	118 000h	at 24V, 15A, 25°C; Ground Fixed GF25		
	95 000h	95 000h	at 24V, 10A, 40°C; Ground Fixed GF40		
	90 000h	90 000h	at 24V, 10A, 40°C; Ground Fixed GF40		

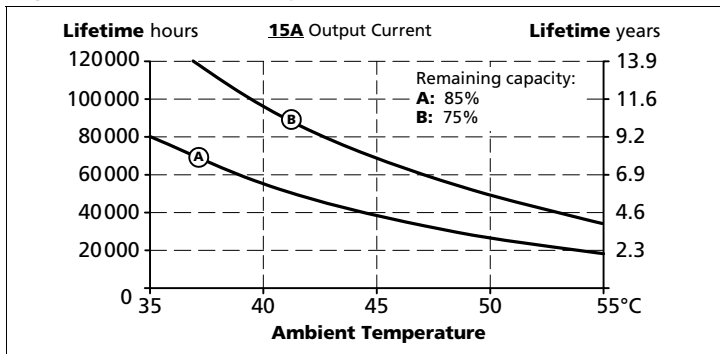
\*) The **Lifetime expectancy** shown in the table indicates the minimum operating hours (service life) and is determined by the lifetime expectancy of the built-in electrolytic capacitors and storage capacitors (ultracapacitors). Lifetime expectancy is specified in operational hours and is calculated according to the capacitor's manufacturer specification.

\*\*) **MTBF** stands for **Mean Time Between Failure**, which is calculated according to statistical device failures, and indicates reliability of a device. It is the statistical representation of the likelihood of a unit to fail and does not necessarily represent the life of a product. The MTBF figure is a statistical representation of the likelihood of a device to fail. A MTBF figure of e.g. 1 000 000h means that statistically one unit will fail every 100 000 units are installed in the field. However, it can not be determined if the failed unit has been running for 50 000h or only for 100h.

**Fig. 11-1 Lifetime expectancy vs. ambient temp. at 10A output current**

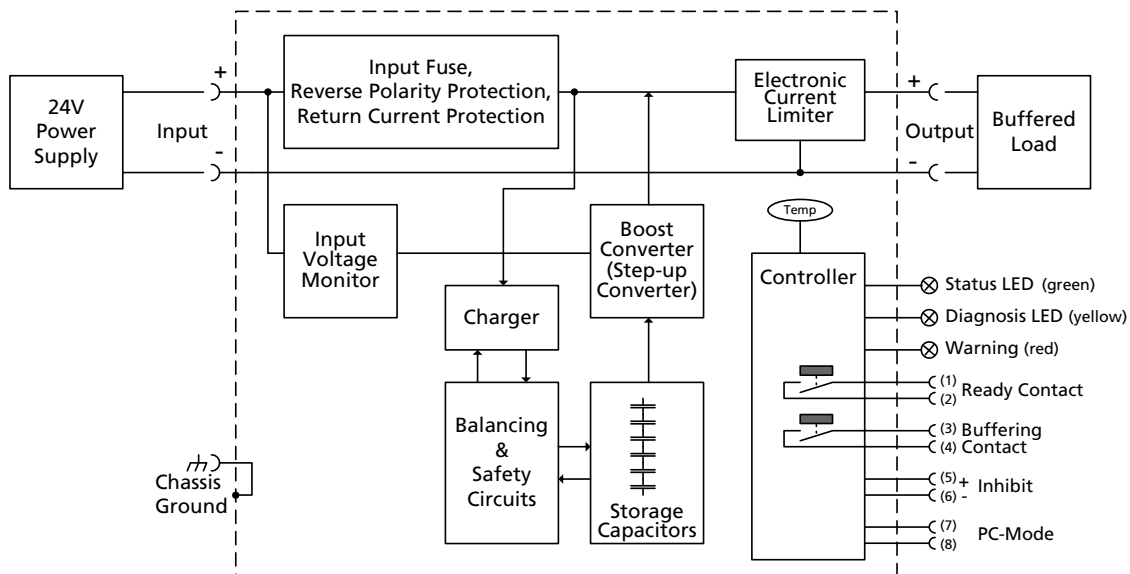


**Fig. 11-2 Lifetime expectancy vs. ambient temp. at 15A output current**



## 12. FUNCTIONAL DIAGRAM

**Fig. 12-1 Functional diagram**



### 13. TERMINALS AND WIRING

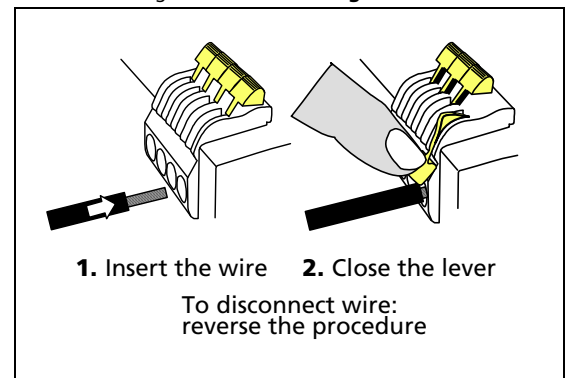
The terminals are IP20 finger safe constructed and suitable for field and factory wiring.

	Input and output	Signals
<b>Type</b>	bi-stable quick-connect spring-clamp terminals	pluggable spring-clap terminals
Solid wire	max. 6mm <sup>2</sup>	max. 1.5mm <sup>2</sup>
Stranded wire	max. 4mm <sup>2</sup>	max. 1.5mm <sup>2</sup>
American Wire Gauge	AWG 20-10	AWG 24-14
Max. wire diameter	2.8mm (including ferrules)	1.5mm (including ferrules)
Wire stripping length	10mm / 0.4inch	8mm / 0.3inch
Screwdriver	-	2.5mm slotted

**Instructions:**

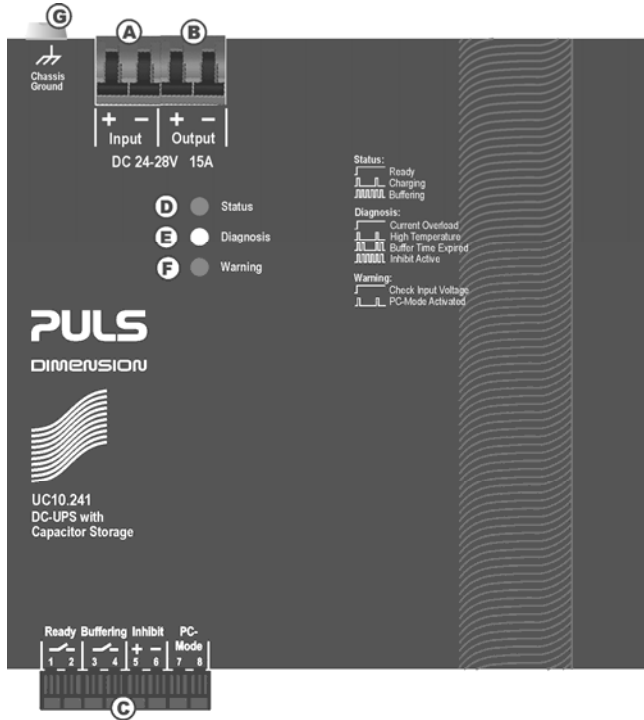
- a) Use appropriate copper cables that are designed for minimum operating temperatures of:  
60°C for ambient up to 45°C and  
75°C for ambient up to 60°C and  
90°C for ambient up to 70°C minimum.
- b) Follow national installation codes and installation regulations!
- c) Ensure that all strands of a stranded wire enter the terminal connection!
- d) Unused terminal compartments should be securely tightened or closed.
- e) Ferrules are allowed.

Fig. 13-1 **Connecting a wire**



### 14. FRONT SIDE AND USER ELEMENTS

Fig. 14-1 Front side (UC10.241)



**A Input Terminals** (quick-connect spring-clamp terminal)

**B Output Terminals** (quick-connect spring-clamp terminal)  
The minus-pole has the same reference as the minus-pole of the input terminals

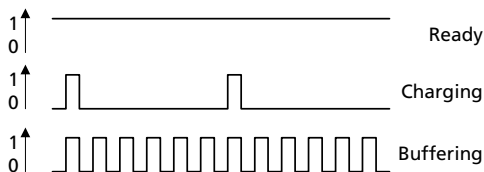
**C Signal Connector** (plug connector)

- **Ready:** contact is closed when status LED indicates ready
- **Buffering:** contact is closed during buffering
- **Inhibit:** a voltage applied on this input signal disables buffering (e.g. during service)
- **PC-Mode:** To activate the PC-mode connect the two pins of the signal connector together; see also section 9.

**D Status LED** (green)

- **Ready:** capacitors are fully charged, no failures detected
- **Charging:** capacitors are being charged
- **Buffering:** capacitors are being discharged

Flashing pattern for the green status LED:

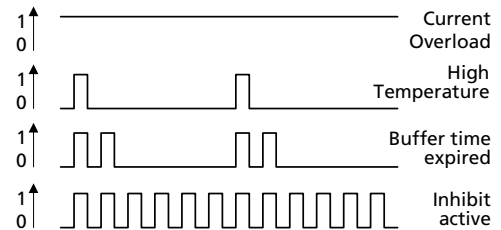


**E Diagnosis LED** (yellow)

Helps troubleshooting and indicates the following:

- **Current Overload:** output voltage below 20Vdc due to a too high output current, ready contact is open
- **High Temperature:** signal for too high capacitor temperature (>65°C), charging and buffering is still possible, ready contact is open
- **Buffer Time Expired:** buffering stopped due to discharged capacitors
- **Inhibit Active:** buffering is blocked by the inhibit signal

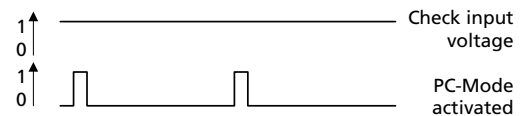
Flashing pattern for the yellow diagnosis LED:



**F "Warning" LED** (red)

- **Check Input Voltage:** Indicates a too low or too high input voltage. The input voltage must be between 23Vdc and 30Vdc to turn-on the output and to start charging of the capacitors.
- **PC-Mode Activated** Indicates, that the PC-Mode (see also section 9) is activated.

Flashing pattern for the red warning LED:



**G Chassis Ground** (screw)  
Use a M4 ring-type terminal to connect the housing to ground, when required

### 15. EMC

The DC-UPS is suitable for applications in industrial environment as well as in residential, commercial and light industry environment without any restrictions.

<b>EMC Immunity</b>	According generic standards: EN 61000-6-1 and EN 61000-6-2			
Electrostatic discharge	EN 61000-4-2	contact discharge *)	8kV	Criterion A
		air discharge *)	15kV	Criterion A
Electromagnetic RF field	EN 61000-4-3	80MHz-2.7GHz	10V/m	Criterion A
Fast transients (Burst)	EN 61000-4-4	input lines	2kV	Criterion A
		output lines	2kV	Criterion A
		signals **)	2kV	Criterion A
Surge voltage on input	EN 61000-4-5	+ → -	500V	Criterion A
		+ / - → chassis ground	1kV	Criterion A
Surge voltage on output	EN 61000-4-5	+ → -	500V	Criterion A
		+ / - → chassis ground	1kV	Criterion A
Surge voltage on inhibit input, ready- and buffering contacts and PC-mode selector	EN 61000-4-5	signals → chassis ground	1kV	Criterion A
Conducted disturbance	EN 61000-4-6	0.15-80MHz	10V	Criterion A

\*) Chassis ground connection earthed (grounded)

\*\*) Tested with coupling clamp

**Criteria:**

**A:** DC-UPS shows normal operation behavior within the defined limits.

<b>EMC Emission</b>	According generic standards: EN 61000-6-3 and EN 61000-6-4		
Conducted emission	IEC/CISPR 16-1-2, IEC/CISPR 16-2-1	input lines	limits for DC power ports acc. EN 61000-6-3 fulfilled
	IEC/CISPR 16-1-2, IEC/CISPR 16-2-1	output lines	limits for DC power ports acc. EN 61000-6-3 fulfilled
Radiated emission	EN 55011, EN 55022		Class B

This device complies with FCC Part 15 rules.

Operation is subjected to following two conditions: (1) this device may not cause harmful interference, and (2) this device must accept any interference received, including interference that may cause undesired operation.

<b>Switching Frequencies</b>	The unit has two converters with two different switching frequencies and one switch-mode current limiter included.	
Switching frequency 1	100kHz	Boost Converter (active only in buffer mode)
Switching frequency 2	78kHz	Electronic output current limitation
Switching frequency 3	19.5kHz	Charger

### 16. ENVIRONMENT

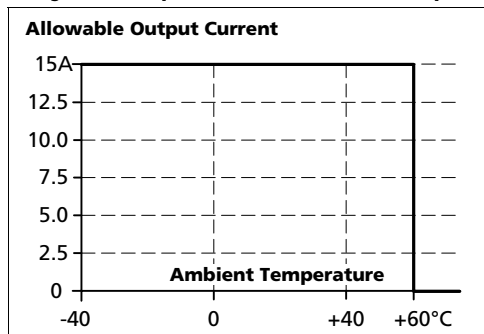
Operational temperature *)	-40°C to +60°C (-40°F to 140°F)	
Storage temperature	-40 to +70°C (-40°F to 158°F)	for storage and transportation
Humidity **)	5 to 95% r.H.	IEC 60068-2-30
Vibration sinusoidal	2-17.8Hz: ±1.6mm; 17.8-500Hz: 2g ***) 2 hours / axis	IEC 60068-2-6
Shock	30g 6ms, 20g 11ms ***) 3 bumps / direction, 18 bumps in total	IEC 60068-2-27
Altitude	0 to 6000m (0 to 20 000ft)	Approvals apply only up to 2000m
Over-voltage category	II	IEC 62103, EN 50178, EN 60950, UL 840
Degree of pollution	2	IEC 62103, EN 50178, not conductive
LABS compatibility	The unit does not release any silicone or other LABS-critical substances and is suitable for use in paint shops.	

\*) Operational temperature is the same as the ambient or surrounding temperature and is defined as the air temperature 2cm below the unit.

\*\*\*) Do not energize while condensation is present

\*\*\*) Higher levels allowed when using the wall mounting bracket ZM2.WALL

Fig. 16-1 **Output current vs. ambient temp.**



### 17. PROTECTION FEATURES

Output protection	Electronically protected against overload, no-load and short-circuits *)	
Output over-voltage protection in buffer mode	typ. 32Vdc max. 35Vdc	In case of an internal DC-UPS defect, a redundant circuit limits the maximum output voltage. The output shuts down and automatically attempts to restart.
Degree of protection	IP 20	EN/IEC 60529 For use in a controlled environment according to CSA 22.2 No 107.1-01.
Penetration protection	> 3.5mm	e.g. screws, small parts
Over-temperature protection	included	Output shuts down with automatic restart
Input over-voltage protection	-	Max. 35Vdc, no harm or defect of the unit
Internal input fuse	included	Non user replaceable The tripping of this fuse is caused by an internal defect. In such cases, send unit to the factory for inspection.
Internal capacitor fuse	included	Non user replaceable The tripping of this fuse is caused by an internal defect. In such cases, send unit to the factory for inspection.
Overcharging of capacitors	included	The capacitors are permanently monitored. In case of a too high charging voltage, the charger will be switched off with redundant protection measures.
Balancing of capacitors	included	An active balancing circuit ensures uniform capacitor voltages. If necessary, the charging current will be reduced to a safe value.
Failing of one or more capacitor in the capacitor-string	included	Ready contact open, moving light pattern on the three LEDs
Temperature of capacitors	included	Indicated by the diagnosis LED, ready contact open
Internal errors (broken wires, ...)	included	Charging is stopped, ready contact open, moving light pattern on the three LEDs

\*) In case of a protection event, audible noise may occur.



### 18. SAFETY FEATURES

Output voltage	SELV	IEC/EN 60950-1, The input must be powered from a SELV power source.
	PELV	IEC/EN 60204-1, EN 50178, IEC 62103, IEC 60364-4-41, The input must be powered from a PELV power source.
Class of protection	III	PE (Protective Earth) connection not required
Isolation resistance	> 5MΩ	Power port to signal port
	> 800kΩ	Power port to housing
	> 5MΩ	Signal port to housing
Dielectric strength	500Vac	Power port to signal port
	500Vac	Power port / signal port to housing
Touch current (leakage current)	The leakage current which is produced by the DC-UPS itself depends on the input voltage ripple and need to be investigated in the final application. For a smooth DC input voltage, the produced leakage current is less than 100µA.	

### 19. APPROVALS

EC Declaration of Conformity		The CE mark indicates conformance with the - EMC directive and the - RoHS directive.
IEC 60950-1 2 <sup>nd</sup> Edition		CB Scheme, Information Technology Equipment Applicable for altitudes up to 2000m.
UL 508		Listed for use as Industrial Control Equipment; U.S.A. (UL 508) and Canada (C22.2 No. 107-1-01); E-File: E198865
UL 60950-1 2 <sup>nd</sup> Edition		Recognized for use as Information Technology Equipment, Level 5; U.S.A. (UL 60950-1) and Canada (C22.2 No. 60950-1); E-File: E137006 Applicable for altitudes up to 2000m.
ANSI / ISA 12.12.01-2007 Class I Div 2		Recognized for use in Hazardous Location Class I Div 2 T4 Groups A,B,C,D systems; U.S.A. (ANSI / ISA 12.12.01-2007) and Canada (C22.2 No. 213-M1987)
EN 60079-0, EN 60079-15 ATEX	 II 3G Ex nA nC II T4 Gc	Approval for use in hazardous locations Zone 2 Category 3G. Number of ATEX certificate: EPS 15 ATEX 1 025 X The power supply must be built-in in an IP54 enclosure.
IEC 60079-0, IEC 60079-15		Suitable for use in Class 1 Zone 2 Groups IIa, IIb and IIc locations. Number of IECEx certificate: IECEx EPS 15.0049X
EAC TR Registration (only for CP10.241)		Registration for the Eurasian Customs Union market (Russia, Kazakhstan, Belarus)

### 20. ROHS, REACH AND OTHER FULFILLED STANDARDS

RoHS Directive		Directive 2011/65/EU of the European Parliament and the Council of June 8 <sup>th</sup> , 2011 on the restriction of the use of certain hazardous substances in electrical and electronic equipment.
REACH Directive		Directive 1907/2006/EU of the European Parliament and the Council of June 1 <sup>st</sup> , 2007 regarding the Registration, Evaluation, Authorisation and Restriction of Chemicals (REACH)

### 21. PHYSICAL DIMENSIONS AND WEIGHT

Weight	UC10.241: 1150g / 2.54lb UC10.242: 1720g / 3.79lb
DIN-Rail	Use 35mm DIN-rails according to EN 60715 or EN 50022 with a height of 7.5 or 15mm. The DIN-rail height must be added to the unit depth (127mm) to calculate the total required installation depth.
Installation Clearances	See chapter 2.

Fig. 21-1 **Front view UC10.241**

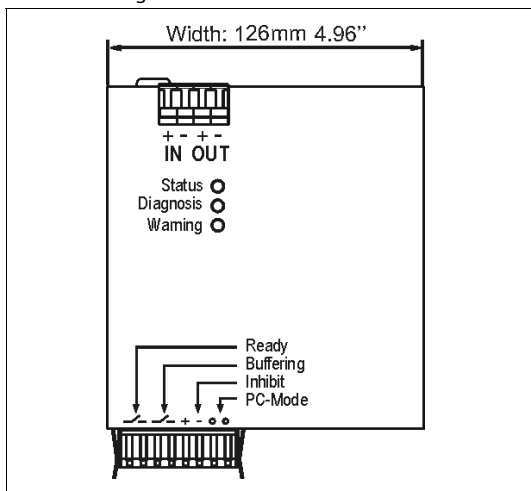


Fig. 21-2 **Front view UC10.242**

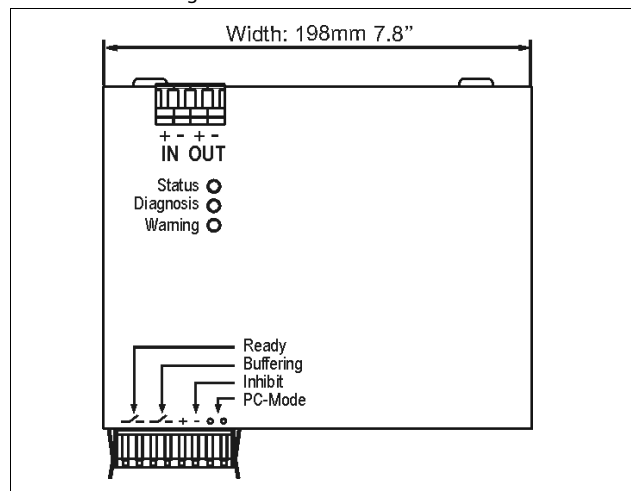
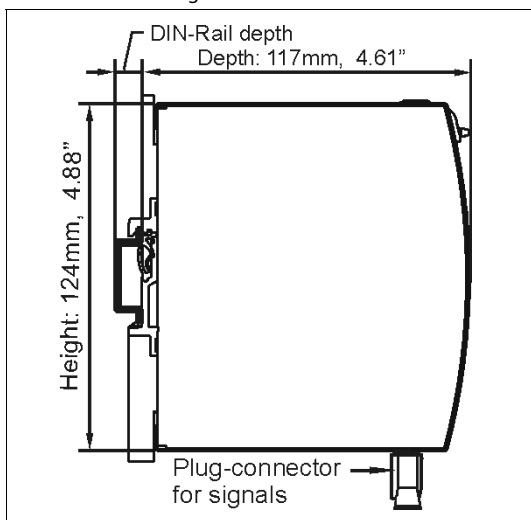


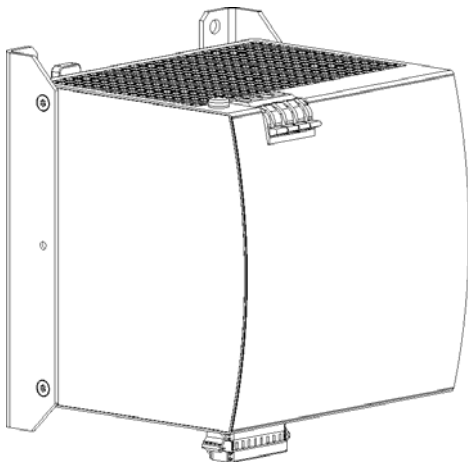
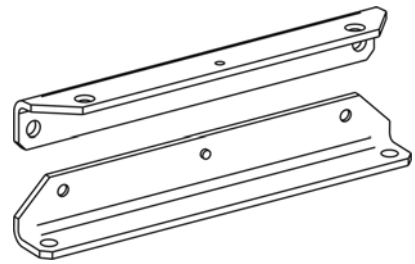
Fig. 21-3 **Side view**



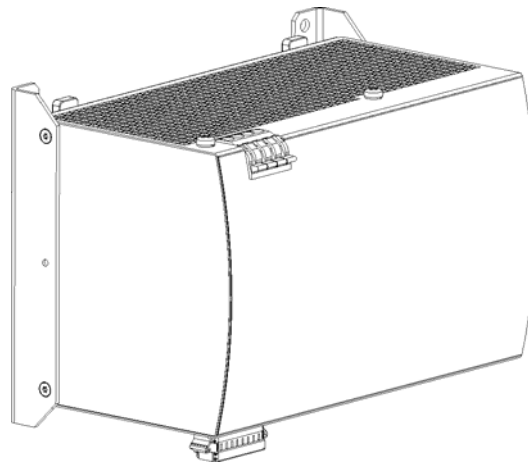
## 22. ACCESSORIES

### 22.1. ZM2.WALL – WALL-MOUNTING BRACKET

This bracket is used to mount the DC-UPS onto a flat surface without utilizing a DIN-Rail.



UC10.241



UC10.242

## 23. APPLICATION NOTES

### 23.1. EXTERNAL INPUT PROTECTION

The DC-UPS is tested and approved for branch circuits up to 50A. An external protection is only required, if the supplying branch has an ampacity greater than this. If an external fuse is necessary or utilized, minimum requirements need to be considered to avoid nuisance tripping of the circuit breaker. A minimum value of 20A B- or C-Characteristic breaker should be used.

Check also local codes and local requirements. In some countries local regulations might apply.

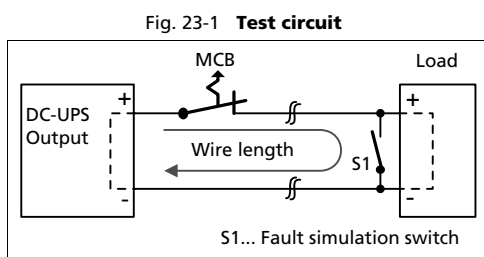
### 23.2. OUTPUT CIRCUIT BREAKERS

The output of the DC-UPS is equipped with an electronic current limitation. An overload or short-circuit on the output is electronically protected and cannot cause any harms, independent of which sizes of power supplies are used on the input of the DC-UPS.

However, some applications require branch circuit or branch circuit conductor protection. Therefore standard miniature circuit breakers (MCB's or UL 1077 circuit breakers) are commonly used on 24V branches.

MCB's are designed to protect wires and circuits. If the ampere value and the characteristics of the MCB are adapted to the wire size that is used, the wiring is considered as thermally safe regardless of whether the MCB opens or not.

To avoid voltage dips and under-voltage situations in adjacent 24V branches which are supplied by the same source, a fast (magnetic) tripping of the MCB is desired. A quick shutdown within 10ms is necessary corresponding roughly to the ride-through time of PLC's. This requires high peak currents to open the circuit breaker in the required time. Furthermore, the impedance of the faulty branch must be sufficiently small in order for the current to actually flow. The following table has typical test results showing which C-Characteristic MCBs magnetically trip depending on the wire cross section and wire length.



Maximal wire length\*) for a fast (magnetic) tripping:

	<b>0.75mm<sup>2</sup></b>	<b>1.0mm<sup>2</sup></b>	<b>1.5mm<sup>2</sup></b>	<b>2.5mm<sup>2</sup></b>
<b>C-2A</b>	20m	25m	39m	58m
<b>C-3A</b>	12m	14m	24m	39m
<b>C-4A</b>	3m	3m	4m	4m

\*) Don't forget to consider twice the distance to the load (or cable length) when calculating the total wire length (+ and - wire).

### 23.3. PARALLEL USE TO INCREASE OUTPUT CURRENT

Do not use the DC-UPS in parallel to increase the output power.

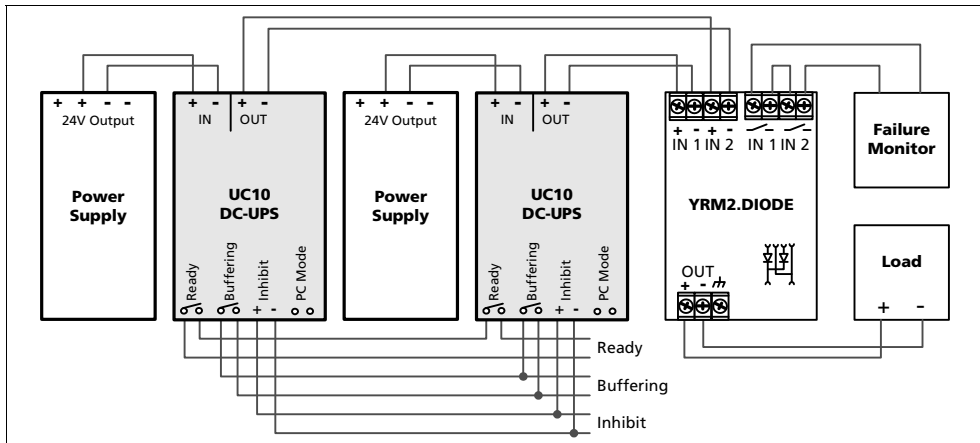
### 23.4. PARALLEL USE FOR REDUNDANCY

Two DC-UPSs can be paralleled to build a 1+1 redundant system to gain higher system reliability.

Recommendations for building redundant power systems:

- a) Use separate input fuses for each power supply.
- b) Set the power supply into "Parallel use" mode if available.
- c) Use a redundancy module to decouple the two power sources.
- d) Monitor the individual sources. Therefore, use the alarm contacts of the YRM2.DIODE redundancy module. (The YRM2.DIODE is suitable for a 10A redundant system)
- e) It is desirable to set the output voltages of all power supplies to the same value ( $\pm 100\text{mV}$ ) or leave it at the factory setting.

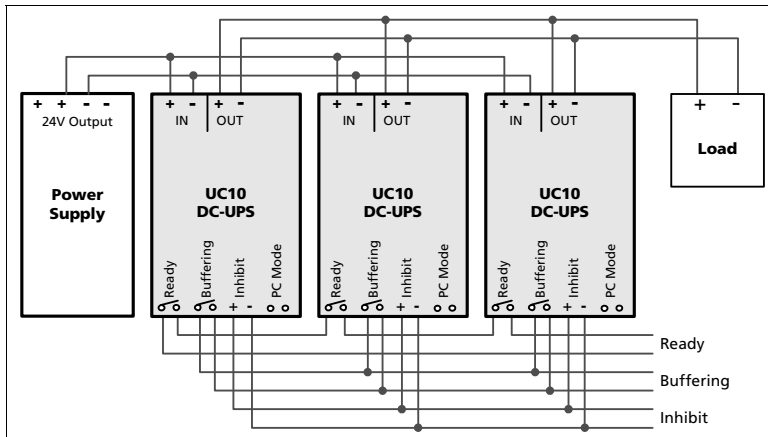
Fig. 23-2 **Wiring example for a fully redundant system, redundant power supplies and redundant DC-UPSs**



### 23.5. PARALLEL USE FOR LONGER BUFFER TIMES

DC-UPSs can be paralleled to extend the buffer time.

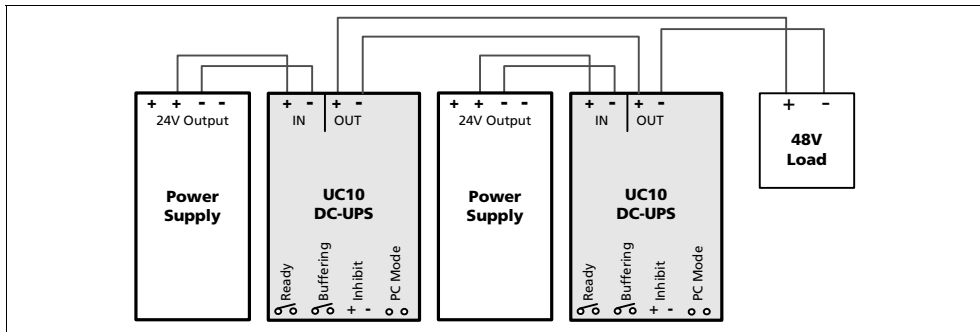
Fig. 23-3 **Wiring example for parallel use for longer buffer times**



### 23.6. SERIES USE FOR 48V APPLICATIONS

A series connection for 48V applications is allowed when utilizing two individual power supplies and two DC-UPSs.

Fig. 23-4 **Wiring example for 48V serial use**

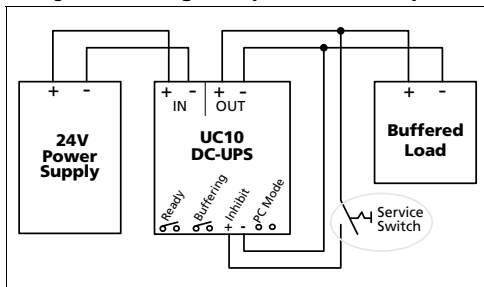


### 23.7. USING THE INHIBIT-INPUT

The inhibit-input disables buffering. In normal mode, a static signal is required. In buffer mode, a pulse with a minimum length of 250ms is required to stop buffering. The inhibit signal is stored and can be reset by cycling the input voltage.

For service purposes, the inhibit input can also be used to connect a service switch. Therefore, the inhibit signal can be supplied from the output of the DC-UPS.

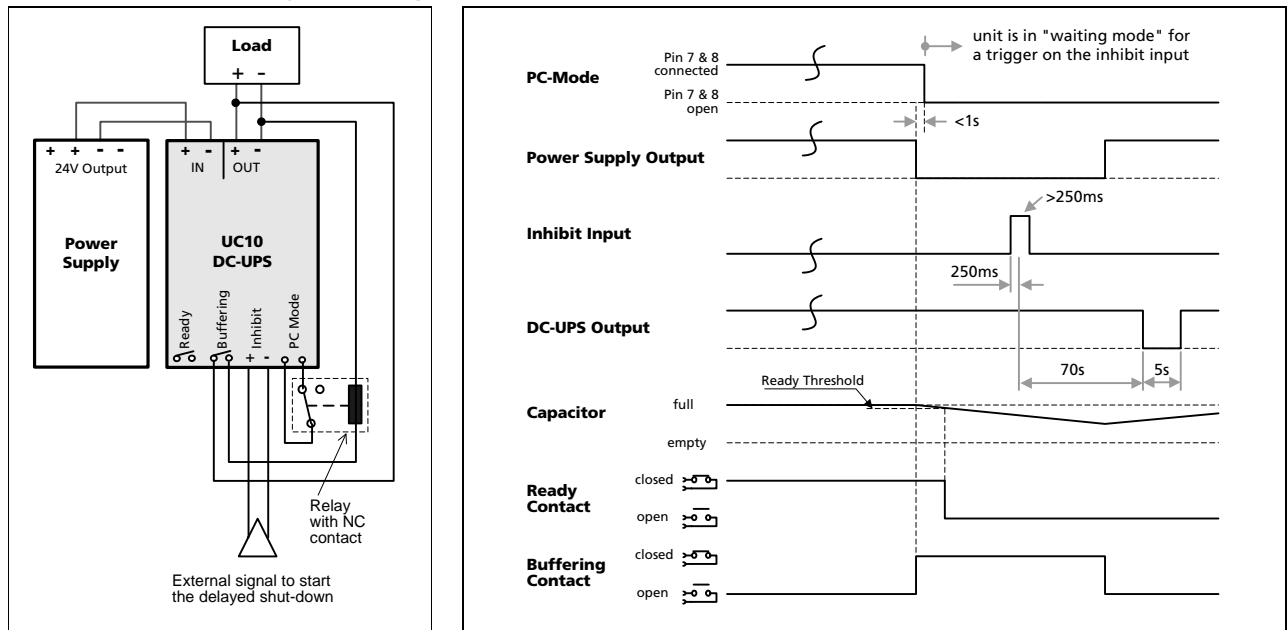
Fig. 23-5 **Wiring example for inhibit input**



### 23.8. EXTERNAL CONTROLLED DELAYED SHUT-DOWN

If the reset is supposed to be controlled by the PC or another external trigger and not the DC-UPS, the following wiring option is possible but requires an external relay:

Fig. 23-6 **Wiring scheme for an external controlled reset after a buffer event**



#### Activation of the "external control mode":

The PC-Mode pins need to be connected together during a normal mode operation. This connection must be opened within the first second of a buffer event to set the DC-UPS into the "external control mode". In this mode, a signal on the inhibit input will not immediately execute a shut-down of the DC-UPS's output but will be delayed by 70s. The output of the DC-UPS will always be switched off for at least 5s.

### 23.9. WHAT DO KJ AND KWS MEAN?

The units kJ (kilo Joule) or kW<sub>s</sub> (kilo Watt seconds) is used for specifying the installed storage capacitor size.

1 kJ = 1 kW<sub>s</sub> = 1000Ws

The stored energy of a capacitor can be calculated with the following formula:

$$Energy(Ws) = \frac{C * U^2}{2}$$

For example: A 350F (Farad) capacitor which is charged to 2.5V has the following energy

$$E = \frac{350F * 2.5V^2}{2} = 1093Ws = 1.09kW_s$$

During discharging of the capacitor, the voltage decreases with the amount of discharge. A boost converter is needed to generate a stable output voltage. The boost converter needs a minimum input voltage (cut-off voltage), which reduces the amount of energy. The cut-off voltage usually depends on the load current, the lower the load current, the lower the cut-off voltage.

Considering this voltage range, the energy can be calculated with the following formula (full charge voltage= U<sub>1</sub>= 2.5V, cut-off voltage= U<sub>2</sub>= 1V):

$$E = \frac{C * (U_1^2 - U_2^2)}{2} = \frac{350 * (2.5^2 - 1^2)}{2} = 919Ws = 0.92kW_s$$

The energy which can be used for the 24V loads is further reduced by the efficiency of the boost converter.

The UC10.241 has a rated capacitor size of 6kW<sub>s</sub> and the UC10.242 12kW<sub>s</sub>. This is the energy which can be used for 24V load at low load currents.

#### Calculation of the needed energy:

Example: A power of 45W is needed for 2 minutes:

$E = P * t = 45 W * 120 s = 5400 Ws = 5.4 kW_s$  Always check with the buffer time curve (see Fig. 6-1) if the load can be powered for the required period of time!

### 23.10. TROUBLESHOOTING

The following guidelines provide instructions for fixing the most common failures and problems. Always start with the most likely and easiest to check condition. Some of the suggestions may require special safety precautions. See notes in section 2 first.

Symptom:	Action:
"Check input voltage" LED is on	- Check input voltage (must be between 22.8V and 30V)
DC-UPS did not buffer	- Inhibit input was set. - Capacitor did not have enough time to be charged.
DC-UPS stopped buffering	- Capacitor was discharged. - Capacitor did not have enough time to be charged. - Inhibit was activated - PC-mode was activated
Output has shut down in normal mode	- Over-temperature protection might have triggered. Let the DC-UPS cool down. - PC-mode was activated (if not longer than 5s)
DC-UPS constantly switches between normal mode and buffer mode	The supplying source on the input is too small and can not deliver sufficient current. Use a larger power supply or reduce the output load